

TOP VIEW

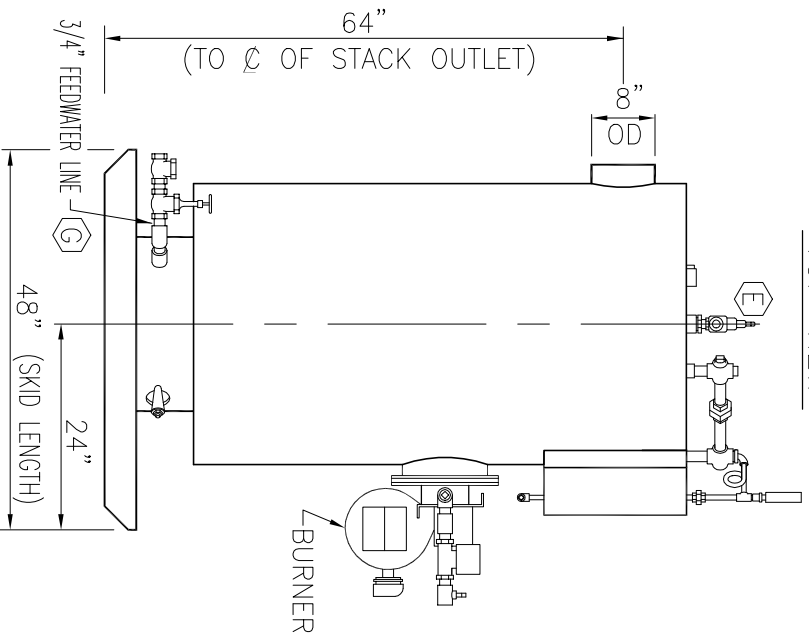

LEFT SIDE VIEW

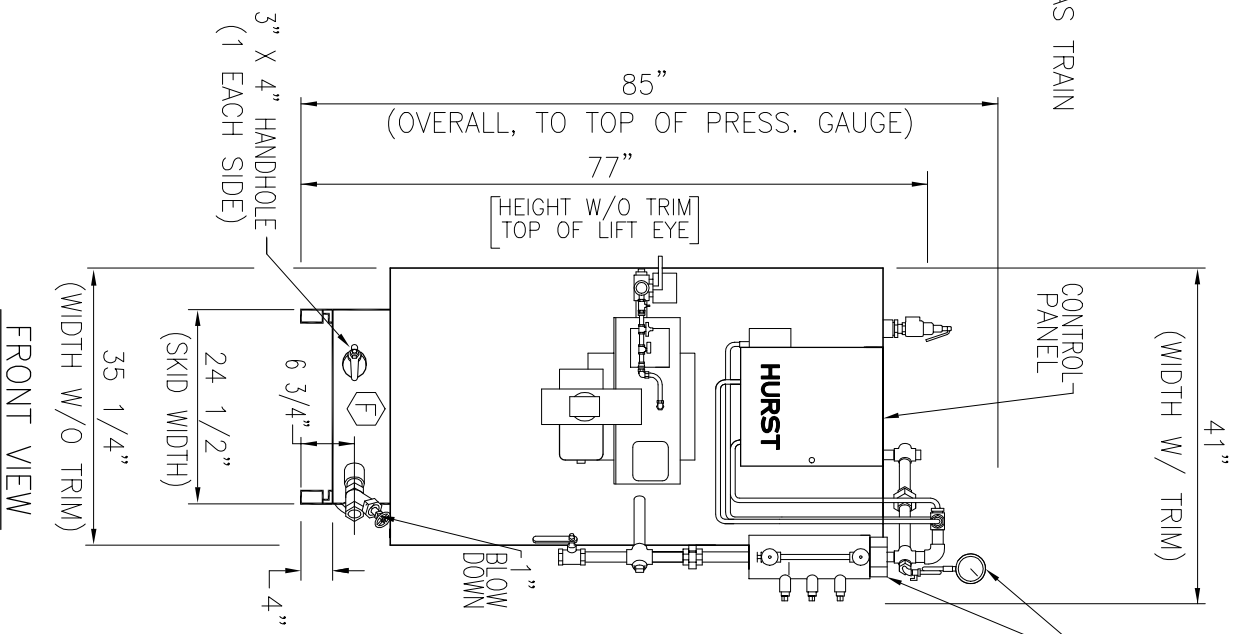

FRONT VIEW

CAPACITIES-OUTPUT	
HORSEPOWER	— 25
LBS./HR. STEAM	— 863
KG./HR. STEAM	— 391
BTU/HR. X 1000	— 837
KCAL/HR. X 1000	— 211
INPUT REQUIRED	
BTU/HR. X 1000	— 1046
KCAL/HR. X 1000	— 264
CONNECTION SIZES	
A	1 1/4" STEAM OUTLET
B	1" SPARE
C	1 1/2" INSPECTION
D	1" FOR PROBE TYPE 2nd
E	LOW WATER CUT-OFF
F	SAFETY VALVE, 1" OUTLET
G	1" BLOWDOWN VALVE
H	3/4" FEEDWATER LINE
I	WATER CAP. AT NWL - 51 GAL.
J	WATER CAP. FLOODED - 77.6 GAL.
J	SHIPPING WEIGHT - 1900 LBS.

**HURST BOILER & WELDING CO., INC.**  
**25 HP - 4 PASS VERTICAL TUBELESS BOILER**  
 150 PSI DESIGN PRESSURE

R	BY:	DATE:	CHK'D:	REASON FOR CHANGE

SCALE:	DWN. BY:	DATE:	CHK'D. BY:	DRAWING NO.:
NTS 24	JHO	11/19/01	RBC	4VT-25-150

THIS DRAWING IS THE PROPERTY OF HURST BOILER AND WELDING CO., INC. AND MAY NOT BE COPIED OR REPRODUCED IN ANY WAY UNLESS AUTHORIZED IN WRITING BY HURST BOILER AND WELDING CO., INC. AND MUST BE RETURNED UPON REQUEST