

LEFT SIDE VIEW

TOP VIEW

DIMENSIONS SUBJECT TO CHANGE WITHOUT NOTICE.
CONSULT FACTORY FOR CERTIFIED DRAWINGS.

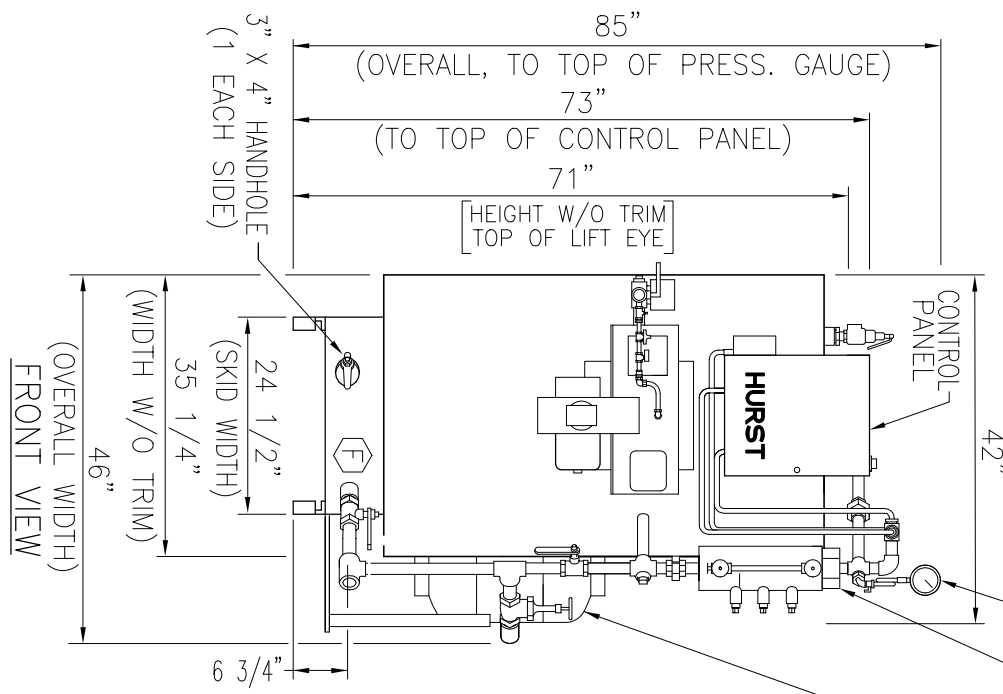

FRONT VIEW

CAPACITIES—OUTPUT

HORSEPOWER	— 15
LBS./HR. STEAM	— 518
KG./HR. STEAM	— 235
BTU/HR. X 1000	— 502
KCAL/HR. X 1000	— 127
INPUT REQUIRED	
BTU/HR. X 1000	— 628
KCAL/HR. X 1000	— 158
CONNECTION SIZES	
A 1" STEAM OUTLET	
B 1" SPARE	
C 1 1/2" INSPECTION	
D 1" FOR PROBE TYPE 2nd	
LOW WATER CUT-OFF	
E SAFETY VALVE, 1" OUTLET	
(1" CPLG.)	
F 1" BLOWDOWN VALVE	
G 3/4" FEEDWATER LINE	
H WATER CAP AT NWL — 54 GAL.	
I WATER CAP AT FLOODED — 68 GAL.	
J SHIPPING WEIGHT	2400 LBS.

4 1/2" DIA. 0-300
PSI PRESS. GAUGE

PUMP CONTROL, WITH
LOW WATER CUT-OFF
AND GAUGE GLASS

8" BLOWDOWN
SEPARATOR
2 1/2" VENT
& 2 1/2" DRAIN

R	BY: DATE: CHK'D:	REASON FOR CHANGE

HURST BOILER & WELDING CO., INC.
15 HP-4 PASS VERTICAL TUBELESS BOILER
WITH 30 GAL. BOILER FEEDWATER SYSTEM
& 8" DIA. X 26" BLOWDOWN SEPARATOR
150 PSI DESIGN PRESSURE

SCALE: | DWN. BY: | DATE: | CHK'D. BY: | DRAWING NO.: |
NTS 24 | JGF | 10-26-99 | JHO | 4V1--15-150RB

THIS DRAWING IS THE PROPERTY OF HURST BOILER AND WELDING CO., INC. AND MAY NOT BE COPIED OR REPRODUCED IN ANY MANNER UNLESS AUTHORIZED IN WRITING BY HURST BOILER AND WELDING CO., INC. AND MUST BE RETURNED UPON REQUEST.